



# EFL803-HV/1003-HV

High Capacity Electric Counterbalanced  
Forklift 8-10T



Innovation Through Simplicity



EP EQUIPMENT CO.,LTD

V2412.01

[www.ep-equipment.com](http://www.ep-equipment.com)

Email: [info@ep-ep.com](mailto:info@ep-ep.com)

EP Industrial Park, Xiaquan Village, Lingfeng Street, Anji County, Huzhou City,  
Zhejiang Province



# WHY HIGH VOLTAGE?

---

Introducing high-voltage electric forklifts with a complete lineup from 4 to 25-ton load capacities, marking the era of high-voltage high-capacity Li-ion trucks.

This groundbreaking development adopts world-leading high-voltage Lithium-ion power combined with advanced PMSM (Permanent Magnet Synchronous Motor) technology. These high-capacity forklifts ensure triple guarantees of high performance, long running time and safety while aligning with the current trend of green and sustainable development.



# HIGH PERFORMANCE: HIGH SPEED AND HIGH GRADEABILITY

---

High-voltage Li-ion batteries enable more power delivery to motors, improving acceleration and travel speeds for high-capacity trucks. PMSMs complement this with rapid response times, swiftly reaching required speeds and torques. This combination of PMSM and high voltage can provide stable and strong power output, which further gives high-capacity trucks excellent climbing capabilities ensuring that the forklift can cope with various applications with ease.

The high-voltage model offers a 1.5-2 times performance improvement over the low-voltage model. Taking the 10-ton model as an example:

## 100%

Improvement in travel speed for high voltage models in laden and unladen conditions.

## 45%

Faster lifting speed demonstrated by the high-voltage models.

## 45%

Improvement in gradeability when laden for high voltage models.

## 100%

Improvement in gradeability when unladen.



# ENERGY EFFICIENCY: EXTENDED RUNTIME AND FAST CHARGING



High-voltage Li-ion batteries have high energy density and can store more electrical energy within a compact volume. High-voltage systems consume less energy and provide longer battery running time comparing low-voltage systems. Notably, these high-voltage Li-ion batteries boast an impressive cycle life of up to 4000 cycles, ensuring long-term durability and minimizing the need for battery replacements.

The PMSMs incorporate advanced control technology to optimize motor efficiency. Unlike traditional AC motors, PMSMs have higher energy conversion efficiency and reduce energy waste. This means that high-capacity trucks can work continuously for prolonged hours at lower costs.



**4000**

**cycles for high-voltage Li-ion batteries**

Equipped with fast charging capabilities, high-capacity trucks offer a remarkable charging experience. The high-voltage models are compatible with vehicle-grade charging stations and support 1C charging rating, allowing them to be fully charged in as fast as 1-1.2 hours. This minimizes downtime and maximizes productivity, making it ideal for multi-shift operations

Lithium batteries present considerably lower charging costs than fuel expenses. The integration of high-voltage and PMSM technology achieves up to 15% greater electricity savings versus traditional lithium and AC technology configurations. This significantly reduces long-term energy consumption costs.



**1C**  
Charging



**1 hour**  
Fully charged



**15%**  
Energy savings

## Smart and reliable strategy for thermal management

The high-capacity trucks utilize three distinct cooling systems to ensure optimal performance and reliability. Specifically, two water cooling systems are employed for the motor and the battery, while an oil cooling system is dedicated to the hydraulics system.

The water cooling systems provide superior cooling performance, preventing the truck from overheating even under the most demanding conditions or in the heat of summer. Water's higher heat transfer capacity compared to air allows it to dissipate heat more efficiently from critical components like the motor and battery. This efficient heat dissipation helps maintain the battery temperature around 30~35°C, protecting these vital components from overheating and potential damage or failure. Consequently, this enhances the overall reliability and longevity of the high-capacity trucks.

Additionally, water cooling systems typically operate with less noise compared to air cooling systems that rely on high-speed fans. This noise reduction is particularly beneficial in applications where a quieter operation is desirable, such as in urban areas or indoor facilities.

The oil cooling system, on the other hand, is used for the hydraulics system. This system ensures that the hydraulic components remain within optimal temperature ranges, thereby maintaining their efficiency and preventing overheating. By effectively managing the temperature of the hydraulics system, the oil cooling system contributes to the smooth and reliable operation of the truck's hydraulic functions.



## Safety Assured: Battery, motor protection, monitoring and mast buffering

Both high-voltage lithium batteries and PMSM employ multiple protective measures to ensure safe operations including overcharge protection, over-temperature monitoring, short-circuit protection, etc. minimizing the risk of potential hazards and maximizing operational safety.

The central controlling module- VCU (Vehicle Control Unit) extends the safety of the high-voltage forklifts. VCU provides precise control and real-time monitoring of critical parameters to ensure the truck operates within safe limits.

It also features turn speed control, which adjusts the forklift's speed based on the turning angle, ensuring stability during turns. An over-speed alarm alerts the operator if the forklift exceeds the safe speed limit.\*

The high-capacity forklift mast is equipped with a hydraulic buffering system that ensures smooth lifting and lowering of loads. With controlled deceleration, the fork movement is smooth with no abrupt stops that could damage the load or cause operator discomfort. This feature enhances operational safety and prolongs the lifespan of the mast components.

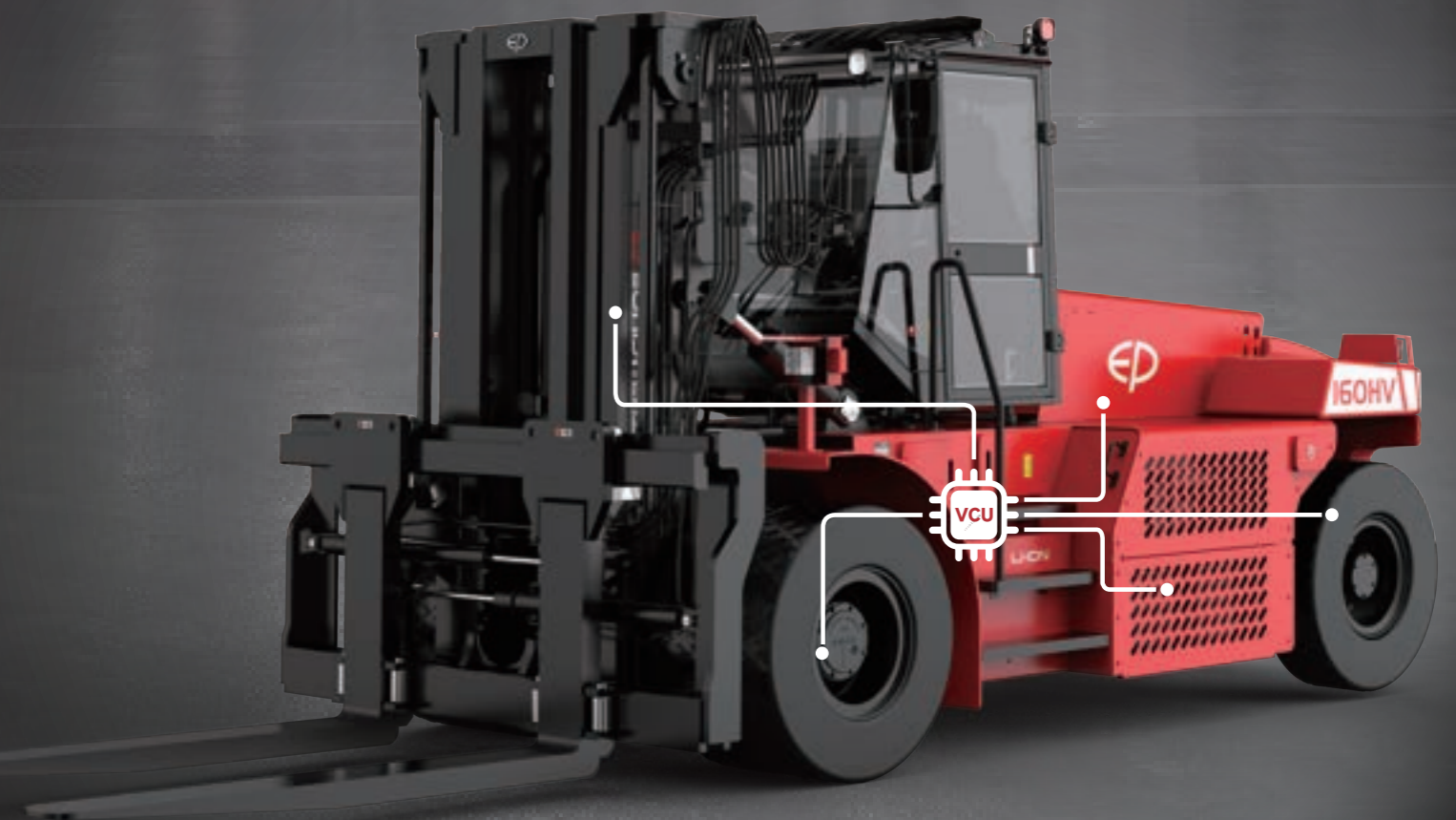

## Low maintenance: Longer battery life span

Operating at a higher voltage allows the battery to be designed with fewer individual cells. With fewer components and a simpler design, the risk of battery failure is lowered.

Thanks to advanced BMS (Battery Management System) which helps to regulate and monitor high-voltage battery, these batteries tend to have a longer life than low-voltage lithium batteries, reducing the need of battery replacement.

The brushless, simple rotor design of PMSM eliminates mechanical wear from brushes and commutators. This durable, low-friction construction requires minimal periodic maintenance, reducing associated labor costs and downtime.



## Sustainability : Zero emissions for cleaner environment

As fully electric trucks powered by lithium-ion batteries, these forklifts produce zero emissions during operation, eliminating exposure to toxic fumes like carbon monoxide and nitrogen oxides.

Unlike lead-acid batteries which can leak corrosive acid, lithium-ion batteries do not risk hazardous spills. The high-capacity li-ion trucks contribute to a cleaner and safer indoor working environment without compromising handling capabilities.



## Strong adaptability adaptable to harsh outdoor weather conditions

Experience uninterrupted productivity through rain, puddles, and damp conditions with the overall IPX4 rating. Plus an exceptional IP67 rating for high-voltage components. Engineered to withstand harsh temperature, high-capacity trucks offer an ambient temperature range of  $-20^{\circ}\text{C}$ - $40^{\circ}\text{C}$  allowing them to perform no matter climate.

Battery heating when charging comes as a standard function for high capacity models, which is activated when the surrounding temperature is below zero to always offer an optimal temperature range for efficient and safe charging even in cold weather conditions.

The dual front wheels is a standard configuration on several models offering a wider base of support, which greatly improves the forklift's stability. Considering the capacity loads of the high-capacity trucks, the weight of the load is more evenly distributed across a larger surface area. The increased ground contact area provided by the dual wheels enhances traction. This is particularly beneficial in environments where the floor may be slippery or uneven while operating outdoors, ensuring that the forklift can maintain a firm grip and operate safely. This not only helps in maintaining balance but also minimizes the stress on individual tires, extending the lifespan of the tires.



## Great support for clients' investment: After-sales Service



### Remote/Online Services:

Telematics technology enables remote monitoring of battery conditions, performance status, and other critical parameters for forklifts. Additionally, production, technical, and after-sales experts are available around the clock to provide prompt and comprehensive solutions for any maintenance issues through virtual support.



### Physical Services:

Comprehensive manuals and supporting documents are provided for all forklift models. In case of breakdowns or replacements, spare parts are swiftly delivered to the clients' locations by global subsidiaries or domestic inventory, minimizing operational disruptions caused by equipment downtime.

# DIVERSE LOADS, WE GOT YOU.

---

EFL803,1003-HV are engineered for the most demanding heavy-duty applications in industries like mining, quarry and stone industry, heavy equipment manufacturing, etc. The dual front wheels offer superior load distribution and stability when handling extraordinarily heavy loads. Despite their compact size and small turning radius, these forklifts boast a high ground clearance, allowing them to navigate challenging terrains with ease. The max travel speed of 30km/h allows the trucks to move swiftly, handling operations efficiently over long distances. Designed with low noise levels, these trucks can provide comfortable working environments for operators, minimizing impacts in noise-sensitive working environments. Additionally, the optional attachment like fork positioner with sideshift enables these forklifts to carry different shapes of loads, enhancing their versatility in handling diverse cargo.



# Everything you want in one truck

## Mast



Lifting and lowering Buffer  
Max Lifting height up to 7000mm\*

## Attachments



Fork positioner with pin type forks  
This versatile combination allows handling different load sizes/positions

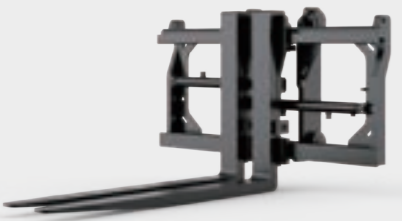

Fork positioner with sideshift: Forks with terminal west\*  
The shaped fork tips facilitate pallet/load entry

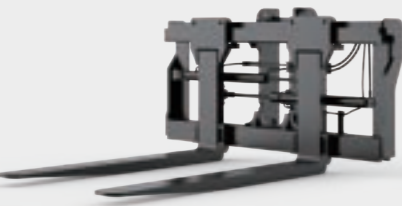

Fork positioner with sideshift: Roller guided forks\*  
Allowing easier pallet/load entry

## Operating Compartment



Cabin with AC and heater\*



Fingertips\*



AC and heater\*



LED Display



Reversing camera\*



## Battery



309V304Ah LFP battery  
Battery heating when charging

## Lights



Front working lights



Strobe warning light



Area warning light\*

The configurations marked with an asterisk (\*) are optional.

# High Capacity Electric Counterbalanced Forklift 8-10T

## EFL803-HV/1003-HV

Distinguishing mark	1.1		EP	EP	EP	
	1.2	Manufacturer		EP	EP	EP
1.3	Model designation		EFL803-HV-6	EFL803-HV-9	EFL1003-HV-6	
1.4	Drive		Electric	Electric	Electric	
1.5	Operator type		Seated	Seated	Seated	
1.6	Load capacity	Q	kg	8000	8000	10000
1.8	Load center distance	c	mm	600	900	600
1.9	Load distance, centre of drive axle to fork	x	mm	708	718	713
2.1	Wheelbase	y	mm	2500	2500	2500
2.2	Service weight		kg	12325	13900	13900
2.3	Axle loading, laden front/rear		kg	18290/2035	19250/2650	21340/2560
2.3	Axle loading, unladen front/rear		kg	6105/6220	6090/7810	6090/7810
3.1	Tyre type		pneumatic	pneumatic	pneumatic	
3.2	Tyre size, front			9.00-20-14PR	9.00-20-14PR	9.00-20-14PR
3.3	Tyre size, rear			9.00-20-14PR	9.00-20-14PR	9.00-20-14PR
3.5	Wheels, number front/rear (x=drive wheels)		mm	4x/ 2	4x/ 2	4x/ 2
3.6	Tread width, front	b10	mm	1600	1600	1600
3.7	Tread width, rear	b11	mm	1700	1700	1700
4.1	Tilt of mast/fork carriage forward/backward	$\alpha/\beta$	°	6/12	6/12	6/12
4.2	Retracted mast height	h1	mm	2850	2850	2850
4.3	Free lift	h2	mm	200	200	200
4.4	Lift height	h3	mm	3000	3000	3000
4.5	Height, mast extended	h4	mm	4310	4310	4310
4.7	Height of overhead guard (cabin)	h6	mm	2680	2680	2680
4.8	Seat height/standing height	h7	mm	1550	1550	1550
4.12	Tow coupling height	h10	mm	630	630	630
4.19	Overall length	l1	mm	5475	5785	5480
4.20	Length to face of forks	l2	mm	3955	3965	3960
4.21	Overall width	b1/b2	mm	2200	2200	2200
4.22	Fork dimensions	s/e/l	mm	75×160×1520	85×160×1820	80×160×1520
4.23	A,B Fork carriage class/type A, B			/	/	/
4.24	Fork carriage width	b3	mm	2130	2130	2130
4.31	Ground clearance, laden, below mast	m1	mm	250	250	250
4.32	Ground clearance, center of wheelbase	m2	mm	345	345	345
4.34.1	Aisle width for pallets 1000×1200 crossways	Ast	mm	6033	6343	6038
4.34.2	Aisle width for pallets 800×1200 lengthways	Ast	mm	6033	6343	6038
4.35	Turning radius	Wa	mm	3605	3605	3605
5.1	Travel speed, laden/unladen		km/ h	29/30	29/30	29/30
5.2	Lifting speed, laden/unladen		m/s	0.39/0.47	0.39/0.47	0.39/0.47
5.3	Lowering speed, laden/unladen		m/s	0.46/0.4	0.46/0.4	0.46/0.4
5.5	Drawbar pull, laden/unladen		N	/	/	/
5.6	Max. drawbar pull, laden/unladen		N	/	/	/
5.8	Max. gradeability, laden/unladen		%	22/30	22/30	22/30
5.10	Service brake			Hydraulic	Hydraulic	Hydraulic
5.11	Parking brake			Mechanical	Mechanical	Mechanical
6.1	Drive motor rating S2 60 min		kW	60	60	60
6.2	Lift motor rating at S3 15%		kW	2x27.8	2x27.8	2x27.8
6.4	Battery voltage/nominal capacity		V/Ah	309V/304AH	309V/304AH	309V/304AH
6.5	Battery weight		kg	860	860	860
8.1	Type of drive control			PMSM	PMSM	PMSM
10.5	Steering design			Hydraulic	Hydraulic	Hydraulic
10.7	Sound pressure level at the driver's ear		dB(A)	/	/	/

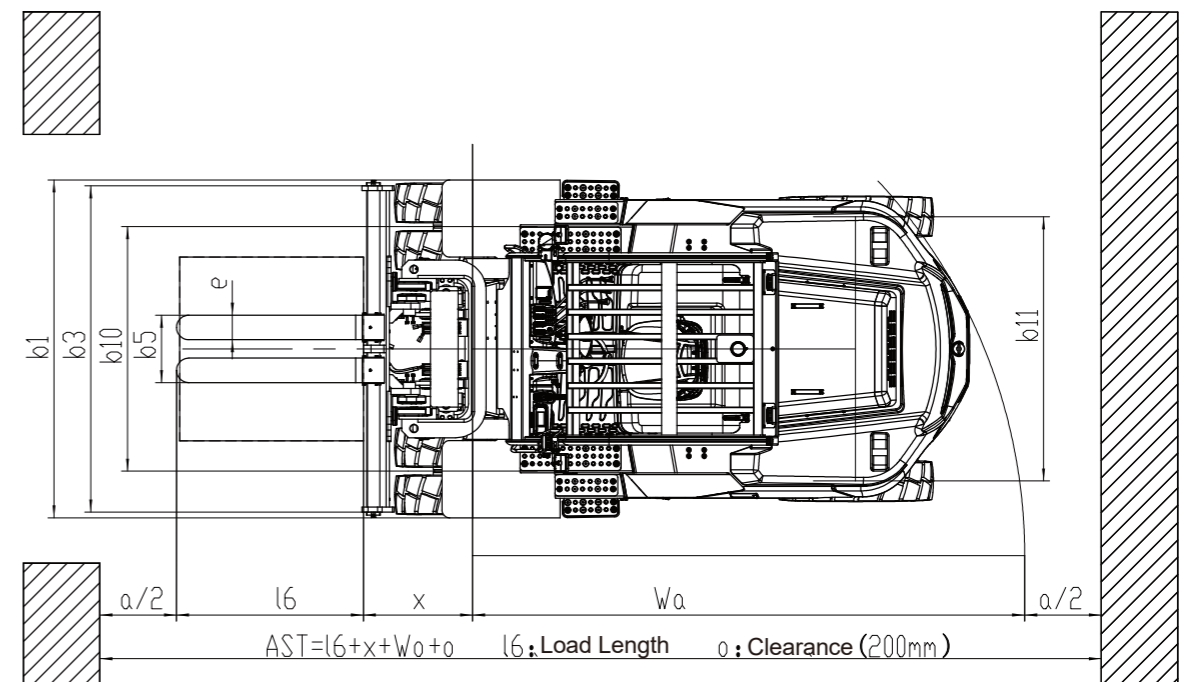
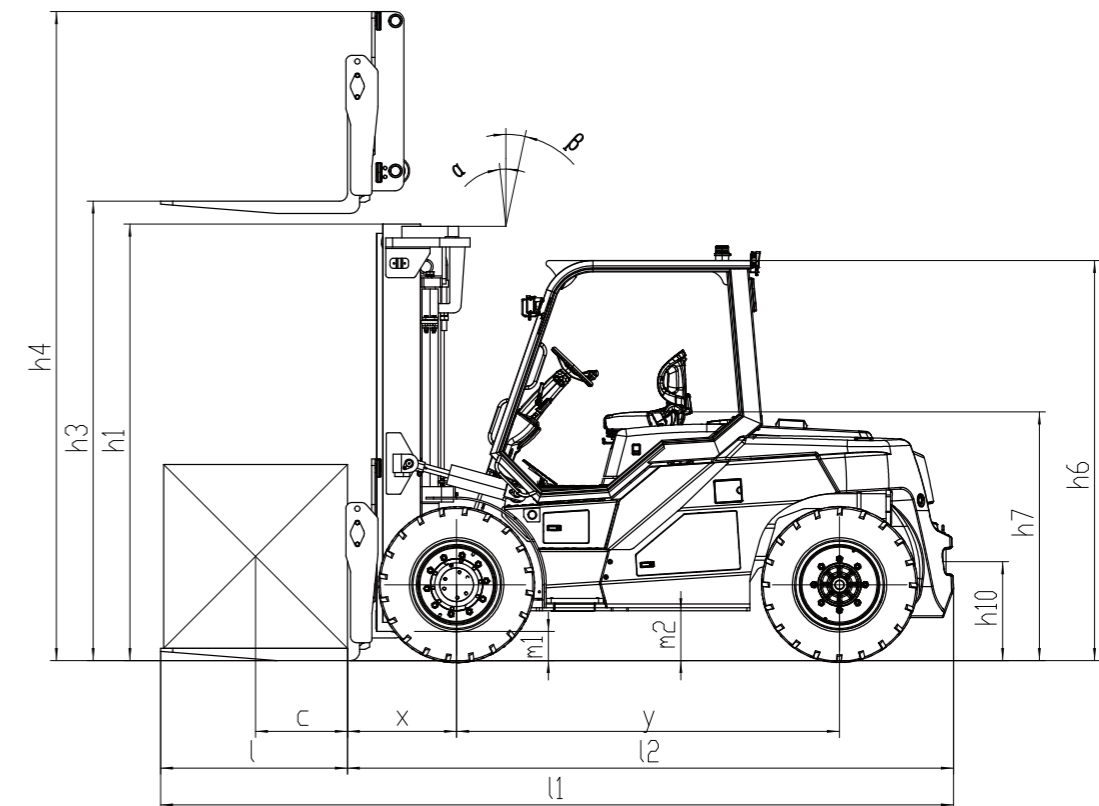

If there are improvements of technical parameters or configurations, no further notice will be given. The diagram shown may contain non-standard configurations.

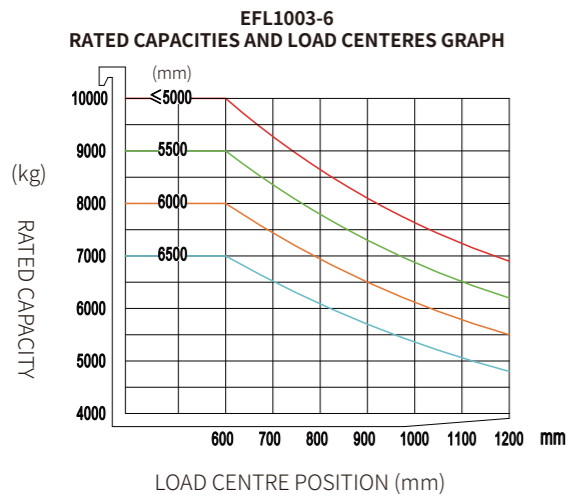
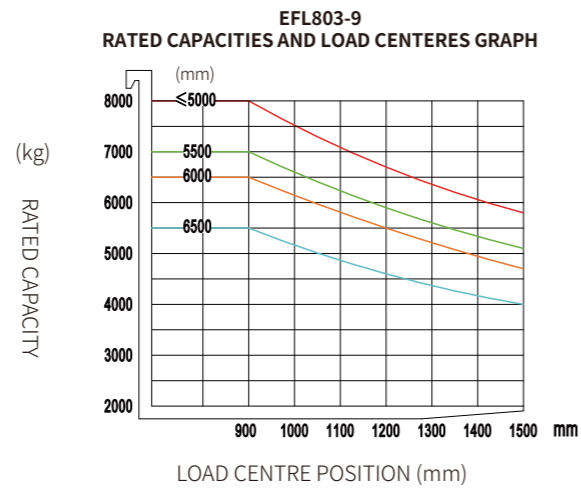
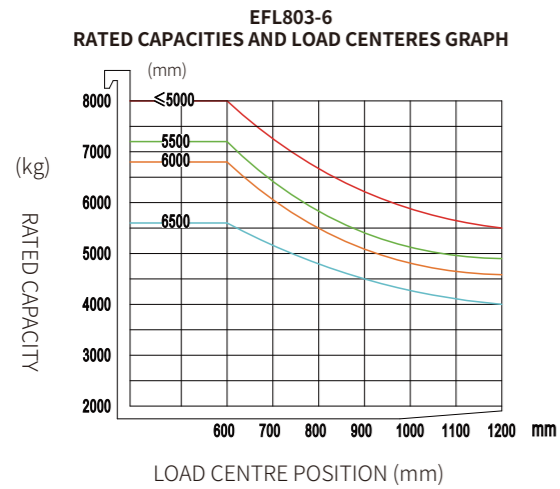

## Mast Option

Mast types	Lift height (h3) mm	Height, Mast			Height, Free lift (h2)	
		Height, mast lowered (h1) mm	Height, mast extended (h4)		No backrest mm	With backrest mm
			No backrest mm	With backrest mm		
2-Standard Mast	3000	2850	4310	—	200	—
	3300	3000	4610	—	200	—
	3500	3100	4810	—	200	—
	4000	3350	5310	—	200	—
	4500	3650	5810	—	200	—
	5000	3900	6310	—	200	—
	5500	4200	6810	—	200	—
	6000	4450	7310	—	200	—
2-Free Mast	3000	2850	4310	—	1305	—
	3500	3100	4810	—	1555	—
	4000	3350	5310	—	1805	—
3-Free Mast	4500	2950	5910	—	1580	—
	4800	3050	6210	—	1680	—
	5000	3116	6410	—	1747	—
	5500	3283	6910	—	1912	—
	6000	3450	7410	—	2080	—
	6500	3616	7910	—	2247	—
	7000	3783	8410	—	2413	—

## Standard Configuration

- Fork positioner with pin type forks
- Fork length 1520mm (600mm LC) / 1820mm (900mm LC)
- 2130mm fork carriage width
- 309V304Ah LFP battery
- Heating system for lithium battery charging
- Telematics
- Mechanical lever
- Buzzer
- Pneumatic tyres
- Standard overhead guard
- Mast lifting and lowering buffer
- Lighting package: LED front working light, turn signal light, market light, LED rear working light, strobe warning light
- Upgraded suspension seat with armrest + headrest + safety belt switch
- Rear grab handle with horn
- OPS system

## Options

- Customized fork length/non-standard accessories
- Customized fork carriage width
- Customized fork backrest
- Attachments:
  - Fork positioner with sideshift: Forks with terminal west
  - Fork positioner with sideshift: Roller-guided forks
- 309V228Ah LFP battery
- Chargers
  - 20kw (3 phase AC 370V-460V, 50-60HZ, 32A plug)
  - 40kw (3 phase AC 370V-460V, 50-60HZ, 63A plug)
- Fingertips
- Solid tyres / non-marking tyres
- Reversing radar/reversing camera/reversing radar and camera
- Lights
  - LED working lights on mast
  - Rotating warning light / rotating buzzer warning light
  - Rear/front and rear blue lamp
  - Front fog light
  - Customized area warning lamp
- Cigarette lighter socket 12V5A
- USB interface 24V
- Turn speed control
- Adjustable overspeed alarm
- Cabin options:
  - Basic half-cabin: front windshield, front wiper (including sprinkler), roof
  - Upgrade half-cabin: basic half-cabin, rear windshield, rear wiper
  - Basic full cabin: upgrade half-cabin, left and right doors, defogging function
  - Upgrade full cabin: basic full cabin, air conditioner
- Grammer MSG65-531 (suspension seat with armrest + safety belt switch)