



EFL403/453/503-HV

EFL503-HV-6/553-HV-6

High Capacity Electric Counterbalanced Forklift 4-5.5T



Innovation Through Simplicity



EP EQUIPMENT CO.,LTD

V2412.01

www.ep-equipment.com

Email: info@ep-ep.com

EP Industrial Park, Xiaquan Village, Lingfeng Street, Anji County, Huzhou City, Zhejiang Province

WHY HIGH VOLTAGE?

Introducing high-voltage electric forklifts with a complete lineup from 4 to 25-ton load capacities, marking the era of high-voltage high-capacity Li-ion trucks.

This groundbreaking development adopts world-leading high-voltage Lithium-ion power combined with advanced PMSM (Permanent Magnet Synchronous Motor) technology. These high-capacity forklifts ensure triple guarantees of high performance, long running time and safety while aligning with the current trend of green and sustainable development.



HIGH PERFORMANCE: HIGH SPEED AND HIGH GRADEABILITY

High-voltage Li-ion batteries enable more power delivery to motors, improving acceleration and travel speeds for high-capacity trucks. PMSMs complement this with rapid response times, swiftly reaching required speeds and torques. This combination of PMSM and high voltage can provide stable and strong power output, which further gives high-capacity trucks excellent climbing capabilities ensuring that the forklift can cope with various applications with ease.

The high-voltage model offers a 1.5-2 times performance improvement over the low-voltage model. Taking the 10-ton model as an example:

100%

Improvement in travel speed for high voltage models in laden and unladen conditions.

45%

Faster lifting speed demonstrated by the high-voltage models.

45%

Improvement in gradeability when laden for high voltage models.

100%

Improvement in gradeability when unladen.



ENERGY EFFICIENCY: EXTENDED RUNTIME AND FAST CHARGING



High-voltage Li-ion batteries have high energy density and can store more electrical energy within a compact volume. High-voltage systems consume less energy and provide longer battery running time comparing low-voltage systems. Notably, these high-voltage Li-ion batteries boast an impressive cycle life of up to 4000 cycles, ensuring long-term durability and minimizing the need for battery replacements.

The PMSMs incorporate advanced control technology to optimize motor efficiency. Unlike traditional AC motors, PMSMs have higher energy conversion efficiency and reduce energy waste. This means that high-capacity trucks can work continuously for prolonged hours at lower costs.



4000

cycles for high-voltage Li-ion batteries

Equipped with fast charging capabilities, high-capacity trucks offer a remarkable charging experience. The high-voltage models are compatible with vehicle-grade charging stations and support 1C charging rating, allowing them to be fully charged in as fast as 1-1.2 hours. This minimizes downtime and maximizes productivity, making it ideal for multi-shift operations

Lithium batteries present considerably lower charging costs than fuel expenses. The integration of high-voltage and PMSM technology achieves up to 15% greater electricity savings versus traditional lithium and AC technology configurations. This significantly reduces long-term energy consumption costs.



1C
Charging



1 hour
Fully charged



15%
Energy savings

Smart and reliable strategy for thermal management

The high-capacity trucks utilize three distinct cooling systems to ensure optimal performance and reliability. Specifically, two water cooling systems are employed for the motor and the battery, while an oil cooling system is dedicated to the hydraulics system.

The water cooling systems provide superior cooling performance, preventing the truck from overheating even under the most demanding conditions or in the heat of summer. Water's higher heat transfer capacity compared to air allows it to dissipate heat more efficiently from critical components like the motor and battery. This efficient heat dissipation helps maintain the battery temperature around 30~35°C, protecting these vital components from overheating and potential damage or failure. Consequently, this enhances the overall reliability and longevity of the high-capacity trucks.

Additionally, water cooling systems typically operate with less noise compared to air cooling systems that rely on high-speed fans. This noise reduction is particularly beneficial in applications where a quieter operation is desirable, such as in urban areas or indoor facilities.

The oil cooling system, on the other hand, is used for the hydraulics system. This system ensures that the hydraulic components remain within optimal temperature ranges, thereby maintaining their efficiency and preventing overheating. By effectively managing the temperature of the hydraulics system, the oil cooling system contributes to the smooth and reliable operation of the truck's hydraulic functions.



Safety Assured: Battery, motor protection, monitoring and mast buffering

Both high-voltage lithium batteries and PMSM employ multiple protective measures to ensure safe operations including overcharge protection, over-temperature monitoring, short-circuit protection, etc. minimizing the risk of potential hazards and maximizing operational safety.

The central controlling module- VCU (Vehicle Control Unit) extends the safety of the high-voltage forklifts. VCU provides precise control and real-time monitoring of critical parameters to ensure the truck operates within safe limits.

It also features turn speed control, which adjusts the forklift's speed based on the turning angle, ensuring stability during turns. An over-speed alarm alerts the operator if the forklift exceeds the safe speed limit.*

The high-capacity forklift mast is equipped with a hydraulic buffering system that ensures smooth lifting and lowering of loads. With controlled deceleration, the fork movement is smooth with no abrupt stops that could damage the load or cause operator discomfort. This feature enhances operational safety and prolongs the lifespan of the mast components.

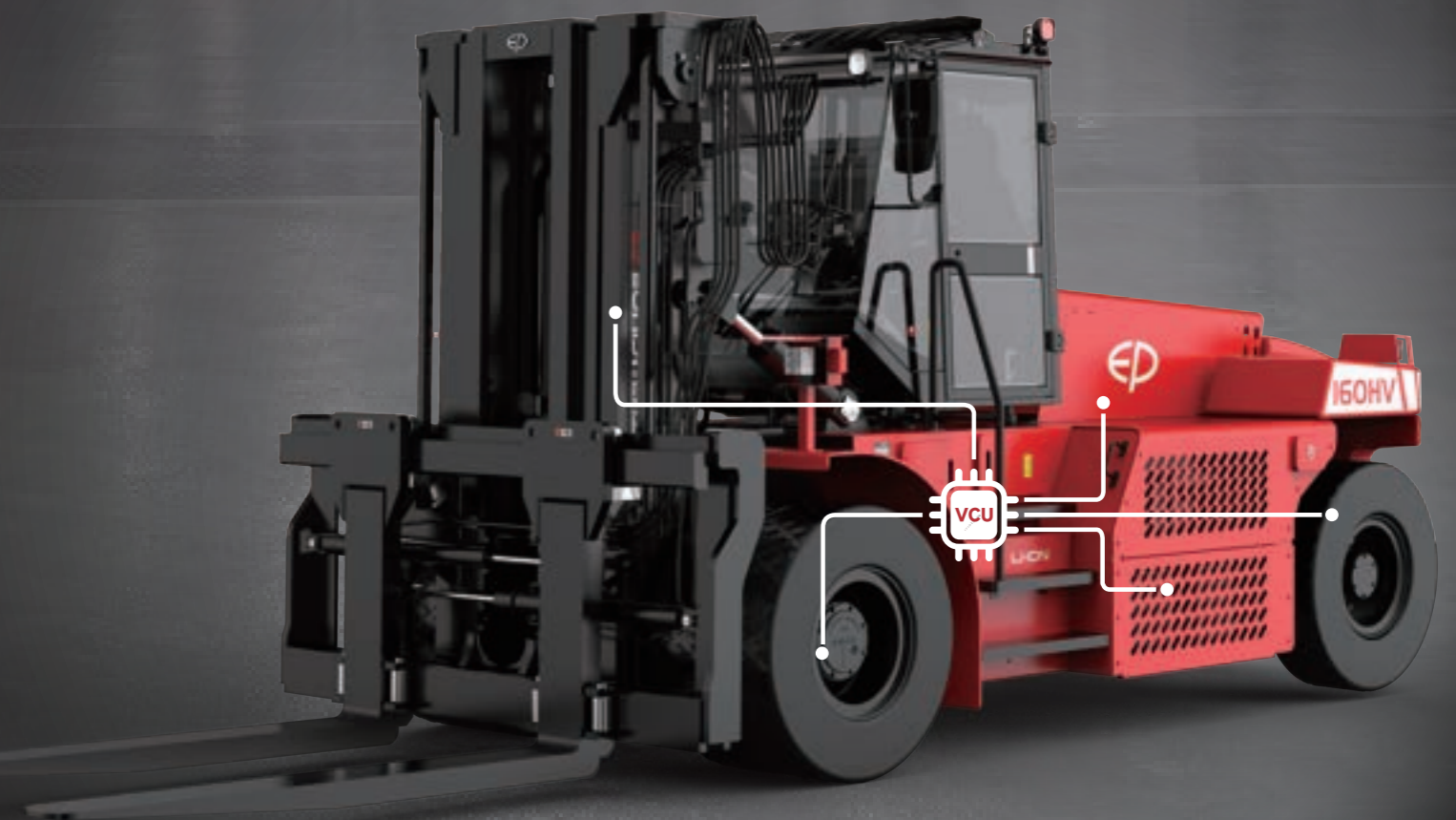

Low maintenance: Longer battery life span

Operating at a higher voltage allows the battery to be designed with fewer individual cells. With fewer components and a simpler design, the risk of battery failure is lowered.

Thanks to advanced BMS (Battery Management System) which helps to regulate and monitor high-voltage battery, these batteries tend to have a longer life than low-voltage lithium batteries, reducing the need of battery replacement.

The brushless, simple rotor design of PMSM eliminates mechanical wear from brushes and commutators. This durable, low-friction construction requires minimal periodic maintenance, reducing associated labor costs and downtime.



Sustainability : Zero emissions for cleaner environment

As fully electric trucks powered by lithium-ion batteries, these forklifts produce zero emissions during operation, eliminating exposure to toxic fumes like carbon monoxide and nitrogen oxides.

Unlike lead-acid batteries which can leak corrosive acid, lithium-ion batteries do not risk hazardous spills. The high-capacity li-ion trucks contribute to a cleaner and safer indoor working environment without compromising handling capabilities.



Strong adaptability adaptable to harsh outdoor weather conditions

Experience uninterrupted productivity through rain, puddles, and damp conditions with the overall IPX4 rating. Plus an exceptional IP67 rating for high-voltage components. Engineered to withstand harsh temperature, high-capacity trucks offer an ambient temperature range of -20°C - 40°C allowing them to perform no matter climate.

Battery heating when charging comes as a standard function for high capacity models, which is activated when the surrounding temperature is below zero to always offer an optimal temperature range for efficient and safe charging even in cold weather conditions.

The dual front wheels is a standard configuration on several models offering a wider base of support, which greatly improves the forklift's stability. Considering the capacity loads of the high-capacity trucks, the weight of the load is more evenly distributed across a larger surface area. The increased ground contact area provided by the dual wheels enhances traction. This is particularly beneficial in environments where the floor may be slippery or uneven while operating outdoors, ensuring that the forklift can maintain a firm grip and operate safely. This not only helps in maintaining balance but also minimizes the stress on individual tires, extending the lifespan of the tires.



Great support for clients' investment: After-sales Service



Remote/Online Services:

Telematics technology enables remote monitoring of battery conditions, performance status, and other critical parameters for forklifts. Additionally, production, technical, and after-sales experts are available around the clock to provide prompt and comprehensive solutions for any maintenance issues through virtual support.



Physical Services:

Comprehensive manuals and supporting documents are provided for all forklift models. In case of breakdowns or replacements, spare parts are swiftly delivered to the clients' locations by global subsidiaries or domestic inventory, minimizing operational disruptions caused by equipment downtime.

COMPACT AND MIGHTY

EFL403-553 HV offer more compact sizes while delivering enhanced performance over low-voltage forklift models. Their single front wheel design allows maneuverability in tighter spaces, making them ideal for industries like steel manufacturing, automotive, and heavy machinery production where space can be limited. With high-voltage Li-ion batteries, EFL403-553 can endure operating hours up to 6 hours. The 20-25% gradeability enables them to handle rough terrain and ramps with ease, making them suitable for outdoor applications with ease.



▣ No detail overlooked in the configurations

Mast



Lifting and lowering Buffer
Max Lifting height up to 7000mm*

Attachments



Fork positioner with pin type forks*
This versatile combination allows handling different load sizes/positions

Operating Compartment



Fingertips*



Rear grab handle with horn



AC and heater*



Reversing radar and camera*



Reversing display*



Battery



309V173Ah LFP battery
Battery heating when charging

Lights



Front working lights



Strobe warning light



Area warning light*

The configurations marked with an asterisk (*) are optional.

High Capacity Electric Counterbalanced Forklift 4-5T EFL403/453/503-HV

			EP				
			EFL403-HV	EFL453-HV	EFL503-HV		
Distinguishing mark	1.1	Manufacturer		EP	EP		
	1.2	Model designation		EFL403-HV	EFL453-HV		
	1.3	Drive		Electric	Electric		
	1.4	Operator type		Seated	Seated		
	1.5	Load capacity	Q	kg	4000	4500	5000
	1.6	Load center distance	c	mm	500	500	500
	1.8	Load distance, centre of drive axle to fork	x	mm	545	545	550
	1.9	Wheelbase	y	mm	2000	2000	2000
	Service weight	2.1	Service weight		kg	6450	6900
2.2		Axle loading, laden front/rear		kg	9442/1008	10267/1133	11064/1286
2.3		Axle loading, unladen front/rear		kg	3352/3098	3415/3485	3439/3911
Tyres/chassis	3.1	Tyre type			pneumatic	pneumatic	pneumatic
	3.2	Tyre size, front			8.25-15-14PR	300-15-20PR	300-15-20PR
	3.3	Tyre size, rear			7.00-12-12PR	7.00-12-12PR	7.00-12-12PR
	3.5	Wheels, number front/rear (x=drive wheels)		mm	2x/ 2	2x/ 2	2x/ 2
	3.6	Tread width, front	b10	mm	1176	1176	1176
	3.7	Tread width, rear	b11	mm	1190	1190	1190
	4.1	Tilt of mast/fork carriage forward/backward	a/β	°	6/12	6/12	6/12
Dimensions	4.2	Retracted mast height	h1	mm	2250	2250	2250
	4.3	Free lift	h2	mm	150	150	155
	4.4	Lift height	h3	mm	3000	3000	3000
	4.5	Height, mast extended	h4	mm	4243/3813	4243/3813	4243/3813
	4.7	Height of overhead guard (cabin)	h6	mm	2400	2400	2400
	4.8	Seat height/standing height	h7	mm	1290	1290	1290
	4.12	Tow coupling height	h10	mm	640	640	640
	4.19	Overall length	l1	mm	4125	4125	4130
	4.20	Length to face of forks	l2	mm	3055	3055	3060
	4.21	Overall width	b1/b2	mm	1495	1495	1495
	4.22	Fork dimensions	s/e/l	mm	50×150×1070	50×150×1070	55×150×1070
	4.23	A,B Fork carriage class/type A, B			/	/	/
	4.24	Fork carriage width	b3	mm	1500	1500	1500
	4.31	Ground clearance, laden, below mast	m1	mm	150	150	150
	4.32	Ground clearance, center of wheelbase	m2	mm	180	180	180
	4.34.1	Aisle width for pallets 1000×1200 crossways	Ast	mm	4495	4495	4550
	4.34.2	Aisle width for pallets 800×1200 lengthways	Ast	mm	4495	4495	4550
4.35	Turning radius	Wa	mm	2680	2680	2730	
Performance data	5.1	Travel speed, laden/unladen		km/ h	24/25	24/25	24/25
	5.2	Lifting speed, laden/unladen		m/s	0.46/0.53	0.43/0.53	0.38/0.48
	5.3	Lowering speed, laden/unladen		m/s	0.41/0.42	0.41/0.42	0.41/0.42
	5.5	Drawbar pull, laden/unladen		N	/	/	/
	5.6	Max. drawbar pull, laden/unladen		N	/	/	/
	5.8	Max. gradeability, laden/unladen		%	25/30	25/28	24/26
Electric-engine	5.10	Service brake			Hydraulic	Hydraulic	Hydraulic
	5.11	Parking brake			Mechanical	Mechanical	Mechanical
	6.1	Drive motor rating S2 60 min		kW	30	30	30
	6.2	Lift motor rating at S3 15%		kW	27.8	27.8	27.8
	6.4	Battery voltage/nominal capacity		V/Ah	309V/173AH	309V/173AH	309V/173AH
Addition data	6.5	Battery weight		kg	473	473	473
	8.1	Type of drive control			PMSM	PMSM	PMSM
	10.5	Steering design			Hydraulic	Hydraulic	Hydraulic
10.7	Sound pressure level at the driver's ear		dB(A)	/	/	/	

If there are improvements of technical parameters or configurations, no further notice will be given.
The diagram shown may contain non-standard configurations.

High Capacity Electric Counterbalanced Forklift 5-5.5T EFL503-HV-6/553-HV-6

			EP			
			EFL503-HV-6	EFL553-HV-6		
Distinguishing mark	1.1	Manufacturer		EP		
	1.2	Model designation		EFL503-HV-6		
	1.3	Drive		Electric		
	1.4	Operator type		Seated		
	1.5	Load capacity	Q	kg	5000	5500
	1.6	Load center distance	c	mm	600	600
	1.8	Load distance, centre of drive axle to fork	x	mm	555	555
	1.9	Wheelbase	y	mm	2000	2000
	Service weight	2.1	Service weight		kg	7600
2.2		Axle loading, laden front/rear		kg	11195/1405	12111/1539
2.3		Axle loading, unladen front/rear		kg	3308/4292	3435/4715
Tyres/chassis	3.1	Tyre type			pneumatic	pneumatic
	3.2	Tyre size, front			300-15-20PR	300-15-20PR
	3.3	Tyre size, rear			7.00-12-14PR	7.00-12-14PR
	3.5	Wheels, number front/rear (x=drive wheels)		mm	2x/ 2	2x/ 2
	3.6	Tread width, front	b10	mm	1176	1176
	3.7	Tread width, rear	b11	mm	1190	1190
	4.1	Tilt of mast/fork carriage forward/backward	a/β	°	6/12	6/12
Dimensions	4.2	Retracted mast height	h1	mm	2500	2500
	4.3	Free lift	h2	mm	160	160
	4.4	Lift height	h3	mm	3000	3000
	4.5	Height, mast extended	h4	mm	4243/3813	4243/3813
	4.7	Height of overhead guard (cabin)	h6	mm	2400	2400
	4.8	Seat height/standing height	h7	mm	1290	1290
	4.12	Tow coupling height	h10	mm	640	640
	4.19	Overall length	l1	mm	4370	4370
	4.20	Length to face of forks	l2	mm	3150	3150
	4.21	Overall width	b1/b2	mm	1495	1495
	4.22	Fork dimensions	s/e/l	mm	60×150×1220	60×150×1220
	4.23	A,B Fork carriage class/type A, B			/	/
	4.24	Fork carriage width	b3	mm	1500	1500
	4.31	Ground clearance, laden, below mast	m1	mm	150	150
	4.32	Ground clearance, center of wheelbase	m2	mm	180	180
	4.34.1	Aisle width for pallets 1000×1200 crossways	Ast	mm	4705	4705
	4.34.2	Aisle width for pallets 800×1200 lengthways	Ast	mm	4705	4705
4.35	Turning radius	Wa	mm	2730	2730	
Performance data	5.1	Travel speed, laden/unladen		km/ h	24/25	24/25
	5.2	Lifting speed, laden/unladen		m/s	0.38/0.48	0.36/0.48
	5.3	Lowering speed, laden/unladen		m/s	0.41/0.42	0.41/0.42
	5.5	Drawbar pull, laden/unladen		N	/	/
	5.6	Max. drawbar pull, laden/unladen		N	/	/
	5.8	Max. gradeability, laden/unladen		%	23/25	20/25
Electric-engine	5.10	Service brake			Hydraulic	Hydraulic
	5.11	Parking brake			Mechanical	Mechanical
	6.1	Drive motor rating S2 60 min		kW	30	30
	6.2	Lift motor rating at S3 15%		kW	27.8	27.8
	6.4	Battery voltage/nominal capacity		V/Ah	309V/173AH	309V/173AH
Addition data	6.5	Battery weight		kg	473	473
	8.1	Type of drive control			PMSM	PMSM
	10.5	Steering design			Hydraulic	Hydraulic
10.7	Sound pressure level at the driver's ear		dB(A)	/	/	

If there are improvements of technical parameters or configurations, no further notice will be given.
The diagram shown may contain non-standard configurations.

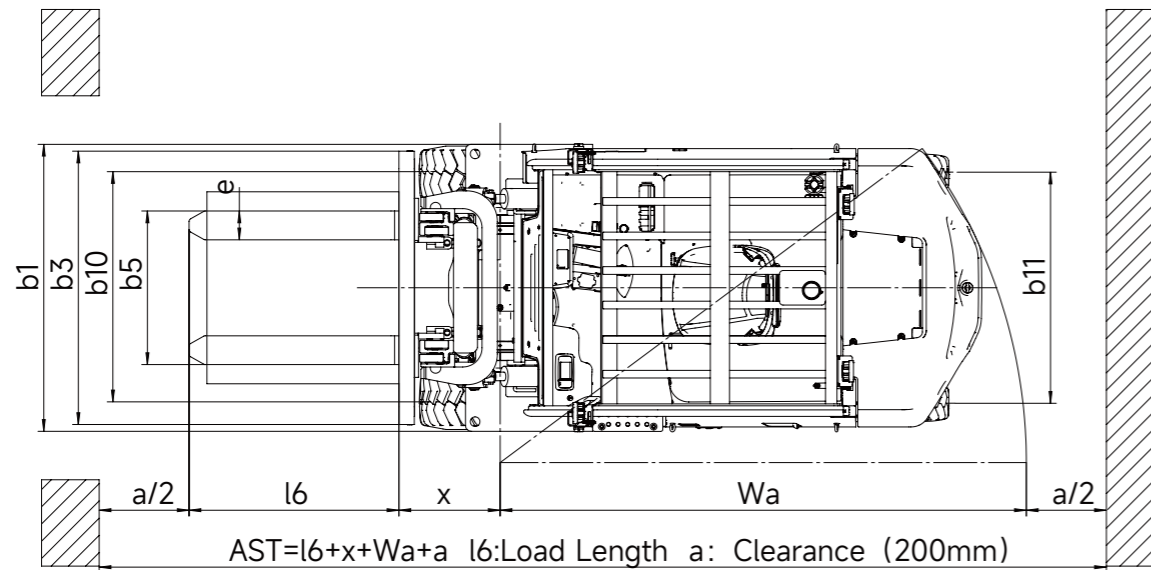
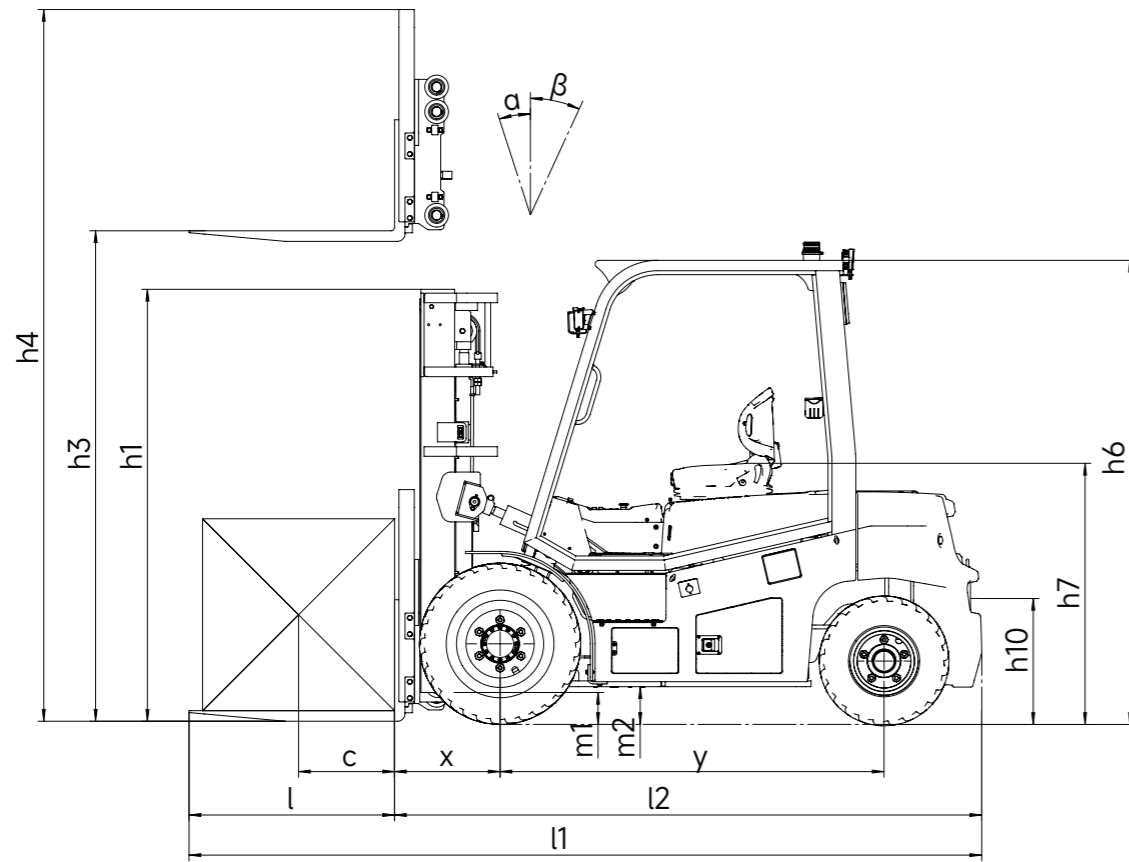

EFL403-HV
RATED CAPACITIES AND LOAD CENTERES GRAPH

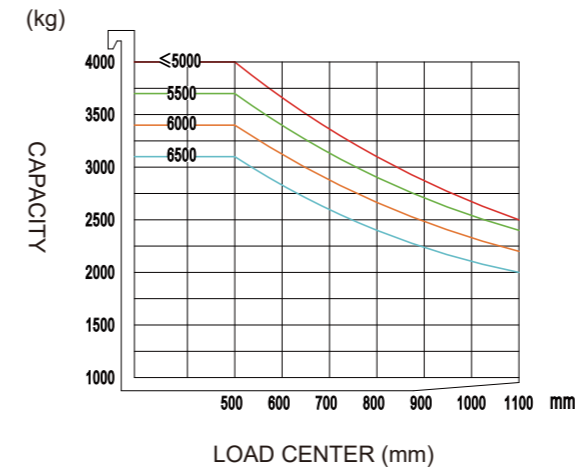

EFL453-HV
RATED CAPACITIES AND LOAD CENTERES GRAPH

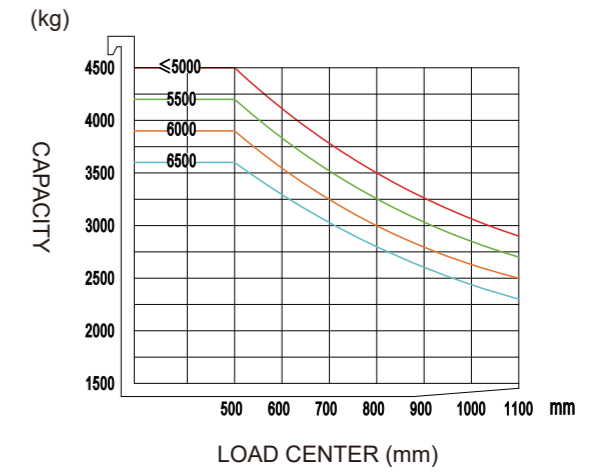

EFL503-HV
RATED CAPACITIES AND LOAD CENTERES GRAPH

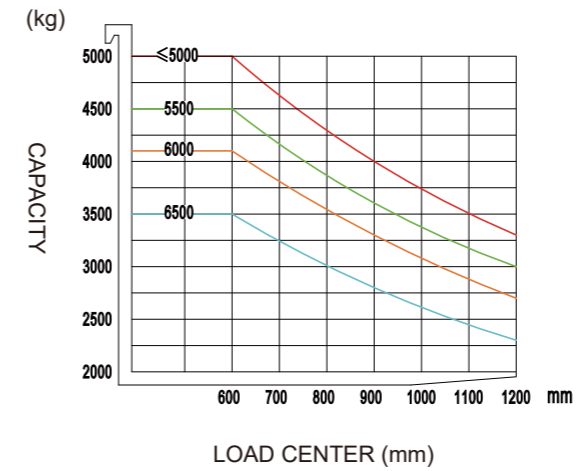

EFL503-HV-6
RATED CAPACITIES AND LOAD CENTERES GRAPH

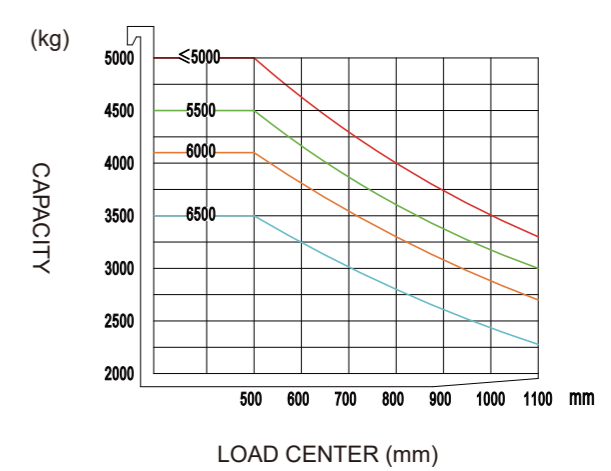

EFL553-HV-6
RATED CAPACITIES AND LOAD CENTERES GRAPH

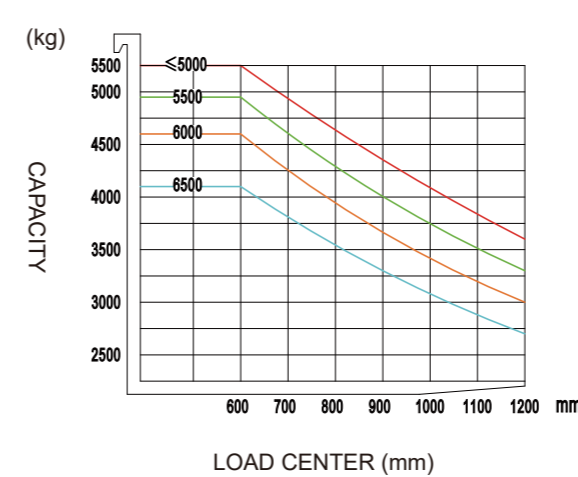

Mast Option

EFL403-HV/EFL453-HV

Mast types	Lift height (h3)	Height, Mast			Height, Free lift(h2)	
		Height, mast lowered(h1)	Height, mast extended(h4)		No backrest	With backrest
			No backrest	With backrest		
mm	mm	mm	mm	mm	mm	
2-Standard Mast	3000	2250	—	4243.5	150	150
	3500	2500	—	4743.5	150	150
	4000	2750	—	5243.5	150	150
	4500	3050	—	5743.5	150	150
	5000	3300	—	6243.5	150	150
	5500	3600	—	6743.5	150	150
	6000	3850	—	7243.5	150	150
	6500	4150	—	7743.5	150	150
2-Free Mast	3000	2250	—	4243.5	860	1364
	3500	2500	—	4743.5	1110	1614
	4000	2750	—	5243.5	—	—
3-Free Mast	4500	2248	5370	5880	—	1390
	5000	2410	5860	6370	—	1552
	5500	2575	6360	6870	—	1718
	6000	2790	6870	7380	—	1932
	6500	2980	7370	7880	—	2123
	7000	3155	7865	8375	—	2298

EFL503-HV/EFL503-HV-6/EFL553-HV-6

Mast types	Lift height (h3)	Height, Mast			Height, Free lift(h2)	
		Height, mast lowered(h1)	Height, mast extended(h4)		No backrest	With backrest
			No backrest	With backrest		
mm	mm	mm	mm	mm	mm	
2-Standard Mast	3000	2250	—	4243.5	155	155
	3500	2500	—	4743.5	155	155
	4000	2750	—	5243.5	155	155
	4500	3050	—	5743.5	155	155
	5000	3300	—	6243.5	155	155
	5500	3600	—	6743.5	155	155
	6000	3850	—	7243.5	155	155
	6500	4150	—	7743.5	155	155
2-Free Mast	3000	2250	—	4243.5	860	1364
	3500	2500	—	4743.5	1110	1614
	4000	2750	—	5243.5	—	—
3-Free Mast	4500	2248	5370	5880	—	1390
	5000	2410	5860	6370	—	1552
	5500	2575	6360	6870	—	1718
	6000	2790	6870	7380	—	1932
	6500	2980	7370	7880	—	2123
	7000	3155	7865	8375	—	2298

Standard Configuration

- Hook-on forks
- 1070mm forks (500mm LC) /1220mm forks (600mm LC)
- 1424mm fork carriage width
- Fork backrest with hook on type fork
- 309V173Ah LFP battery
- Pneumatic tyres
- Buzzer
- Heating system for lithium battery charging
- Telematics
- Mechanical lever
- Rear armrest horn
- Upgrade mechanical suspension seat with armrest + headrest + safety belt switch
- OPS system
- Standard overhead guard
- Mast lifting and lowering buffer
- Lighting package: LED front working light, turn signal light, market light, LED rear working light, strobe warning light

Options

- Customized fork length/non-standard accessories
- Customized fork carriage width
- Customized fork backrest
- Attachments:
 - Hook-on sideshifter
 - Hook-on fork positioner with sideshifter
 - Fork positioner: Pin-type forks
- Chargers
 - 20kw (3 phase AC 370V-460V, 50-60HZ, 32A plug)
 - 40kw (3 phase AC 370V-460V, 50-60HZ, 63A plug)
- Fingertips
- Grammer MSG65-531 mechanical suspension seat with armrest + safety belt switch
- Solid tyres / non-marking tyres
- Reversing radar/reversing camera/reversing radar and camera
- Lights
 - LED working lights on mast
 - Rotating warning light / rotating buzzer warning light
 - Rear/rear and front blue lamp
 - Front fog light
 - Customized area warning light
- Cigarette lighter socket 12V5A
- USB interface 24V
- Turn speed control
- Adjustable overspeed alarm
- Cabin options:
 - Basic half-cabin: front windshield, front wiper (including sprinkler), roof
 - Upgrade half-cabin: basic half-cabin, rear windshield, rear wiper
 - Basic full cabin: upgrade half-cabin, left and right doors, defogging device
 - Upgrade full cabin: basic full cabin, air conditioner